

No.	DATE	MODIFICATION	REASON	MOD. BY
0	09/05/13	Edited in new format.	CAD software change.	E.V.

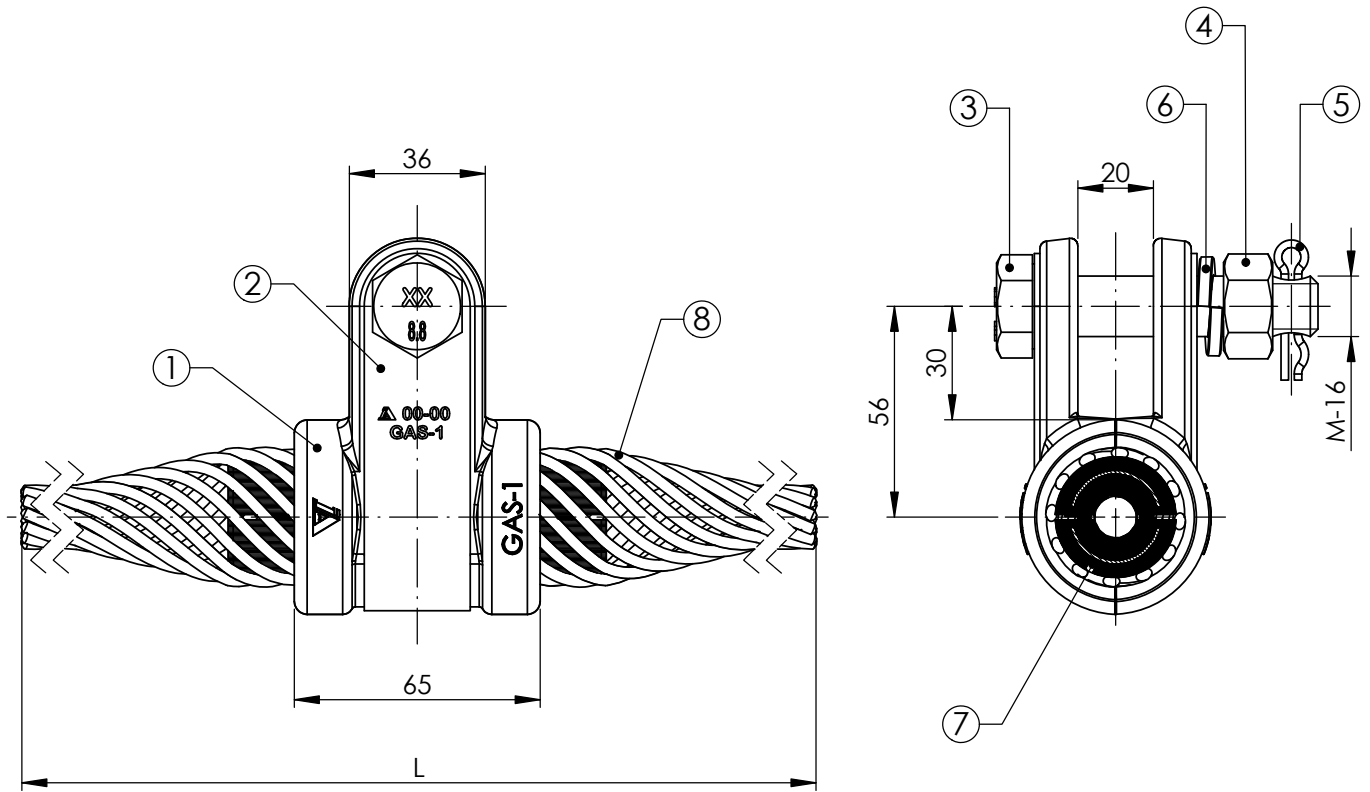

COMPONENT SELECTION TABLE

COMPLETE SET	REFERENCE			APLICACION		Ø (mm.)	Nº ARMOUR RODS	"L" (mm.)	COLOUR	ARMOUR RODS WEIGHT (kg.)
	CLAMP	INSERT	ARMOUR RODS	MIN.	MAX.					
GAS-1/FO/8	GAS-1-SV-SM	MGAS-1/8	VPGS1AL 8/D/1800	Ø 7,76	Ø 8,25	Ø 3,71	8	1800	GREEN	0,50
GAS-1/FO/8,5	GAS-1-SV-SM	MGAS-1/8,5	VPGS1AL 8,5/D/1800	Ø 8,26	Ø 8,75	Ø 3,71	9	1800	BLUE	0,55
GAS-1/FO/9	GAS-1-SV-SM	MGAS-1/9	VPGS1AL 9/D/1800	Ø 8,76	Ø 9,59	Ø 3,71	9	1800	BLACK	0,55
GAS-1/FO/10	GAS-1-SV-SM	MGAS-1/10	VPGS1AL 10/D/1800	Ø 9,60	Ø 10,59	Ø 3,71	10	1800	YELLOW	0,62
GAS-1/FO/11	GAS-1-SV-SM	MGAS-1/11	VPGS1AL 11/D/1800	Ø 10,60	Ø 11,59	Ø 3,71	10	1800	BLUE	0,62

IMPORTANT: DO NOT FORGET TO STATE DIRECTION OF OUTER LAY OF CONDUCTOR

8	No	ARMOUR RODS	ALUMINUM ALLOY	-	EN-50.183	TABLE
7	2	ARMOUR GRIP SUSPENSION CLAMP INSERT	NEOPRENE	-	-	0.04
6	1	SPRING WASHER METRIC 16	GALVANIZED STEEL	0184	DIN-127 B	0.01
5	1	STAINLESS STEEL 4,5x37 SAFETY PIN	STAINLESS STEEL	0027	-	0.00
4	1	NUT METRIC 16+0.6	GALVANIZED STEEL	0025	DIN-934	0.03
3	1	BOLT M16x75 SHANK 47 8.8	GALVANIZED STEEL	0023	DIN-931	0.15
2	1	GAS-1 CLAMP COLLAR	STAINLESS STEEL	1465	EN-10.088-1	0.08
1	2	ARMOUR GRIP SUSPENSION CLAMP BODY	ALUMINIUM ALLOY	1463	EN-1.706	0.13
No.	QTY.	DESCRIPTION	MATERIAL	CODE	STANDARD	WEIGHT (Kg.)
UNITS (mm.)		- Manufactured according to IEC 61284 standard - Tolerances unless otherwise stated to be: Up to and including 35 mm. ±0.7 mm. Over 35 mm. ±2% - Hot dip galvanized according to ISO 1461 standard	- M.B.S.L.: 5.000 daN - M.D.S.L.: 70% M.B.S.L. - lcc: Depend of the connexion to the piece - Coating thickness. Local: 40µm. Average: 50µm	BODY WEIGHT: 0.62 Kg.		
DRAWN BY	E.V.	09/05/2013	ARMOUR GRIP SUSPENSION CLAMP		SCALE	DRAWING ISSUE
SIGNED BY	I.L.	09/05/2013	GAS-1/FO(CONDUCTOR OPGW LAYER RIGHT)		1:2	GAS1FO-M 2

This drawing is property of I. Arruti and must not be copied, exhibited or furnished without the written consent of I. Arruti.



F40513 NAME

DRAWN BY E.V.

SIGNED BY I.L.