

No.	DATE	MODIFICATION	REASON	MOD. BY
0	18/04/13	Edited in new format.	CAD software change.	E.V.
1	14/10/15	N° and colour of armor rods changed.	N° of armour rods valid.	X.E.

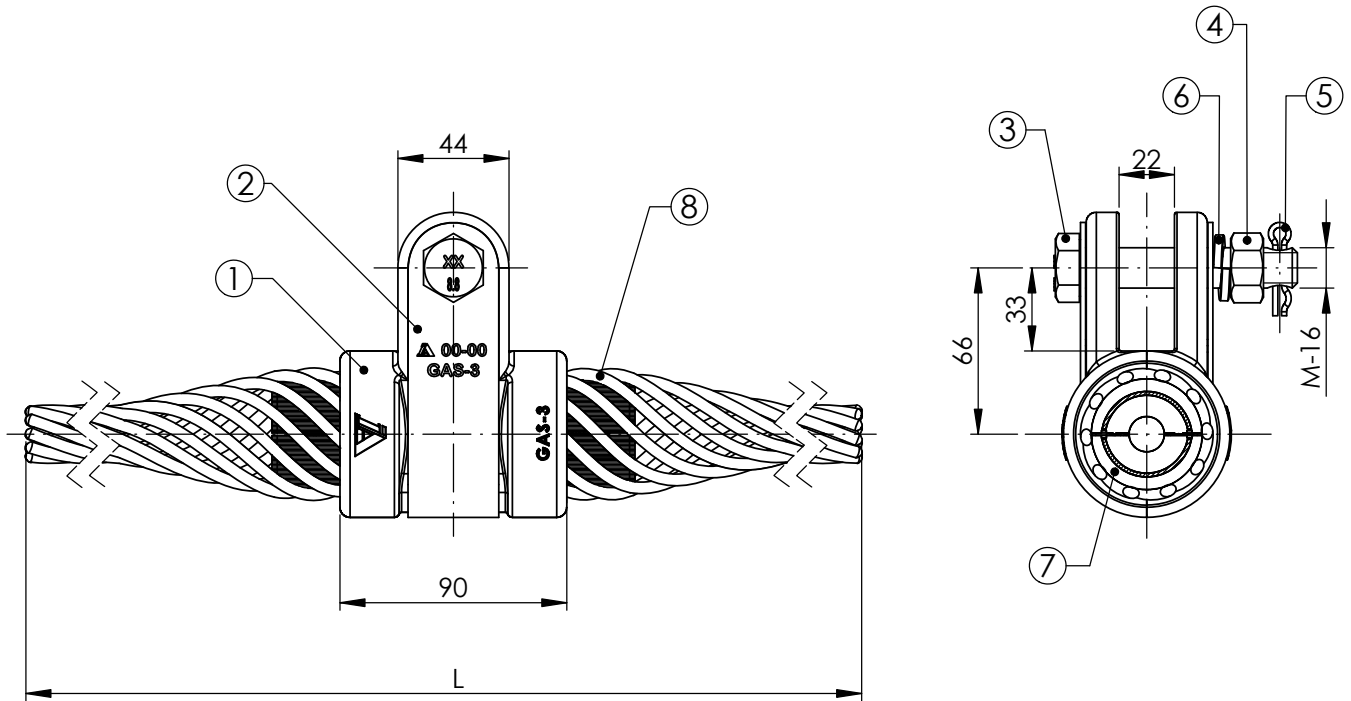

COMPONENT SELECTION TABLE

REFERENCE			RANGE		Ø (mm.)	N° ARMOUR RODS	"L" (mm.)	COLOUR	ARMOUR RODS WEIGHT (kg)	
COMPLETE SET	CLAMP	INSERT	MIN.	MAX.						
GAS-3/FO/12	GAS-3-SV-SM	MGAS-3/12	VPGS3AL 12/D/1800	Ø11,60	Ø12,25	Ø4,62	9	1800	RED	0,74
GAS-3/FO/12,5	GAS-3-SV-SM	MGAS-3/12	VPGS3AL 12,5/D/1800	Ø12,26	Ø12,79	Ø4,62	9	1800	BLUE	0,76
GAS-3/FO/13	GAS-3-SV-SM	MGAS-3/13	VPGS3AL 13/D/1800	Ø12,80	Ø13,69	Ø4,62	10	1800	YELLOW	0,85
GAS-3/FO/14	GAS-3-SV-SM	MGAS-3/14	VPGS3AL 14/D/1800	Ø13,70	Ø14,59	Ø4,62	10	1800	RED	0,87
GAS-3/FO/15	GAS-3-SV-SM	MGAS-3/15	VPGS3AL 15/D/1800	Ø14,60	Ø15,59	Ø4,62	11	1800	BLUE	0,95
GAS-3/FO/16	GAS-3-SV-SM	MGAS-3/16	VPGS3AL 16/D/1800	Ø15,60	Ø16,59	Ø4,62	12	1800	GREEN	1,04

IMPORTANT: DO NOT FORGET TO STATE DIRECTION OF OUTER LAY OF CONDUCTOR

8	No	ARMOUR RODS	ALUMINUM ALLOY	-	EN-50.183	TABLE
7	2	ARMOUR GRIP SUSPENSION CLAMP INSERT	NEOPRENE	-	-	0.11
6	1	SPRING WASHER METRIC 16	GALVANIZED STEEL	0184	DIN-127 B	0.01
5	1	STAINLESS STEEL 4,5x37 SAFETY PIN	STAINLESS STEEL	0027	-	0.00
4	1	NUT METRIC 16+0.6	GALVANIZED STEEL	0025	DIN-934	0.03
3	1	BOLT M16x86 SHANK 52 8.8	GALVANIZED STEEL	0838	DIN-931	0.17
2	1	GAS-3 CLAMP COLLAR	STAINLESS STEEL	-	EN-10.088-1	0.14
1	2	ARMOUR GRIP SUSPENSION CLAMP BODY	ALUMINIUM ALLOY	-	EN-1.706	0.29
No.	QTY.	DESCRIPTION	MATERIAL	CODE	STANDARD	WEIGHT (Kg.)
UNITS (mm.)		- Manufactured according to IEC 61284 standard - Tolerances unless otherwise stated to be: Up to and including 35 mm. ±0.7 mm. Over 35 mm. ±2% - Hot dip galvanized according to ISO 1461 standard		- M.B.S.L.: 7.500 daN - M.D.S.L.: 70% M.B.S.L. - lcc: Depend of the connexion to the piece - Coating thickness. Local: 40µm. Average: 50µm		BODY WEIGHT: 1.15 Kg.
F40513		NAME	ARMOUR GRIP SUSPENSION CLAMP		SCALE	DRAWING ISSUE
DRAWN BY		E.V.	GAS-3/FO(CONDUCTOR OPGW LAYER RIGHT)		1:3	GAS3FO-M 2
SIGNED BY		I.L.				

This drawing is property of I. Arruti and must not be copied, exhibited or furnished without the written consent of I. Arruti.



INDUSTRIAS
ARRUTI S.A.