

No.	DATE	MODIFICATION	REASON	MOD. BY
0	01/03/12	Edited in new format.	CAD software change.	E.V.

MARKINGS:

LOT (month & year)
FORGER MARK
& REFERENCE



This drawing is property of I. Arruti and must not be copied, exhibited or furnished without the written consent of I. Arruti.

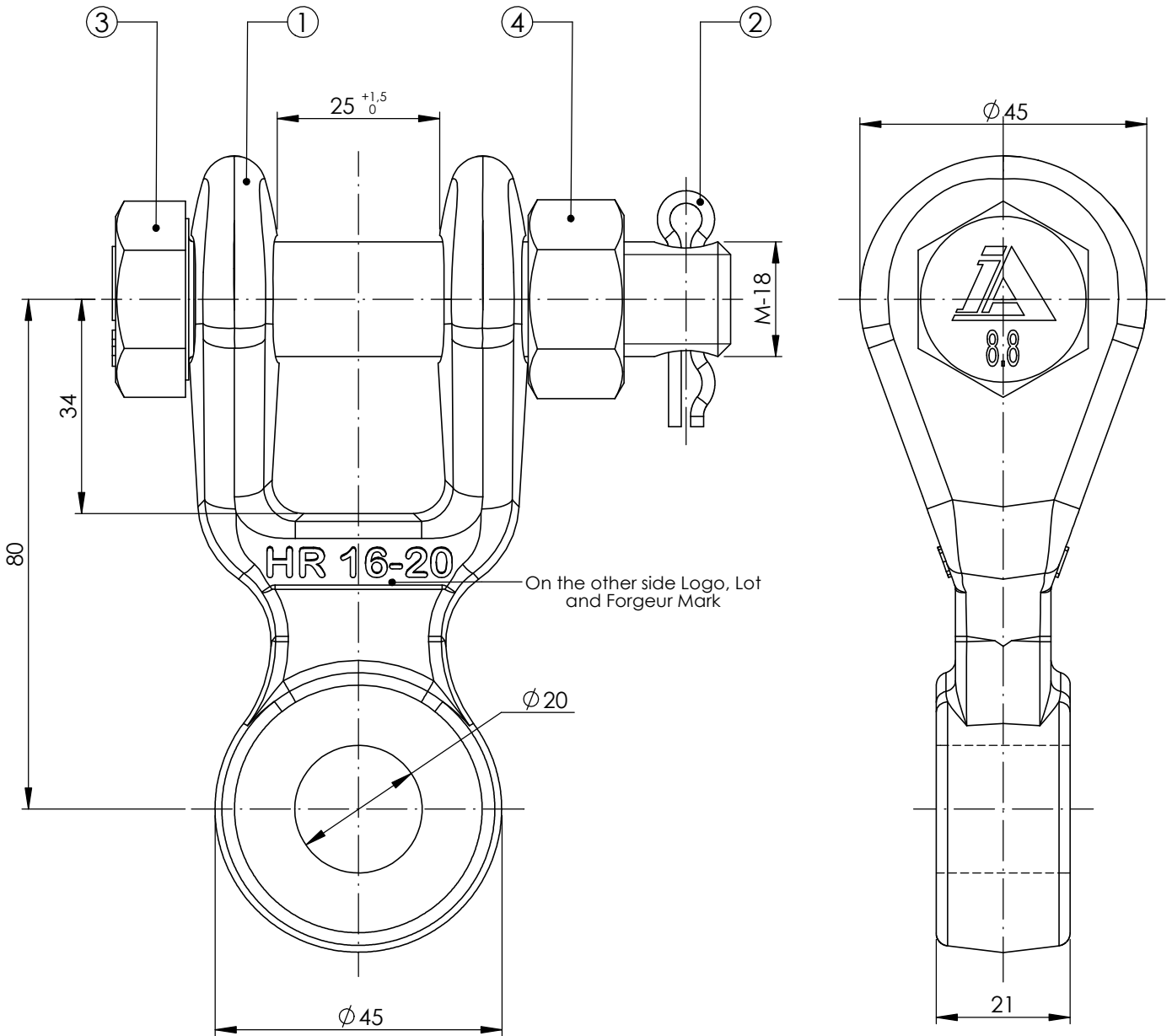

4	1	NUT METRIC 18+0.6	GALVANIZED STEEL	0051	DIN-934	0.05	
3	1	BOLT M18x85 SHANK 56 8.8	GALVANIZED STEEL	0053	DIN-931	0.22	
2	1	STAINLESS STEEL 4,5x37 SAFETY PIN	STAINLESS STEEL	0027	-	0.00	
1	1	SM CLEVIS EYE	GALVANISED STEEL	1115s	EN-10.083-2	0.57	
No.	QTY.	DESCRIPTION	MATERIAL	CODE	STANDARD	WEIGHT (Kg.)	
UNITS (mm.)		- Manufactured according to IEC 61284 standard - Tolerances unless otherwise stated to be: Up to and including 35 mm. ±0.7 mm. Over 35 mm. ±2% - Hot dip galvanized according to ISO 1461 standard	- M.B.S.L.: 18.000 daN - M.D.S.L.: 75% M.B.S.L. - lcc: Depend of the connexion to the piece - Coating thickness. Local: 70µm. Average: 85µm	TOTAL WEIGHT: 0.84 Kg.			
F40513	NAME	TWISTED CLEVIS EYE HR-20/21			SCALE	DRAWING	ISSUE
DRAWN BY	E.V.				01/03/2012	1:1	0074-M
SIGNED BY	I.L.	01/03/2012					



**INDUSTRIAS
ARRUTI S.A.**